

*Shelbourne*  
REYNOLDS

CUBICLE BEDDER



CUBICLE BEDDER

[SHELBOURNE.COM](http://SHELBOURNE.COM)

# Shelbourne

## CUBICLE BEDDER



OPTIONAL 3 POINT LINKAGE HYDRAULIC TIPPING FRAME WITH "A" FRAME ATTACHMENT

THE SHELBOURNE CUBICLE BEDDER IS DESIGNED TO PROVIDE A UNIFORM BED QUICKLY AND EFFICIENTLY WITH A MINIMUM OF OPERATOR EFFORT.



The machine consists of a rugged, welded steel bucket with a 30cm wide, hydraulically driven, cleated belt running in the bottom.

This belt will operate in either direction, allowing the operator to bed cubicles on either side of the machine while keeping dust levels to a minimum.

- SAVE TIME
- SAVE BEDDING, USE UP TO 50% LESS BEDDING MATERIAL
- MORE EVENLY DISTRIBUTED BEDDING
- SAME MACHINE AVAILABLE EITHER AS REAR 3-POINT MOUNTED WITH TIPPING FRAME OR AS FRONT LOADER MOUNTED
- SIMPLE DURABLE DESIGN
- ONE HYDRAULIC FLOW AND RETURN NEEDED

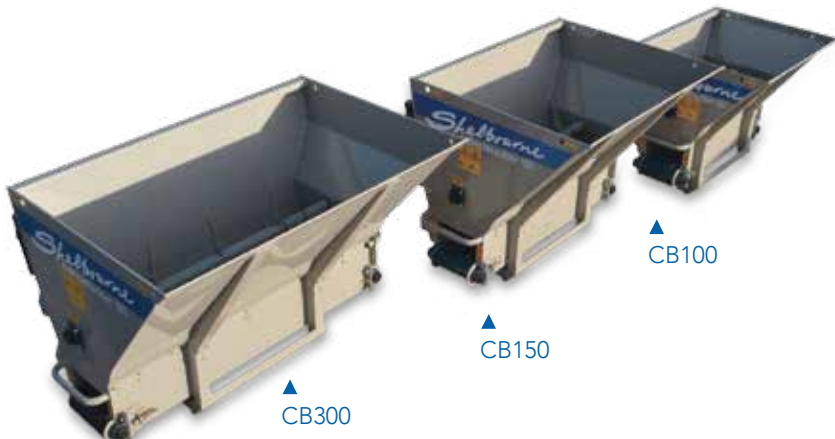

HEAVY DUTY INTERNAL AGITATOR AND DISCHARGE CONTROL SLIDES



The Shelbourne Cubicle Bedder is the most versatile machine of it's type available. Discharge rates can be changed by either adjusting the internal slides, or varying the speed of the belt using the tractor/loader hydraulic flow control. These factors, along with forward speed adjustments gives the operator complete control.

The belt speed can be used to control the distance material is thrown with a maximum of 10ft possible.

A centrally mounted agitator shaft is operated hydraulically above the belt using a common hydraulic supply. Agitator tines can be mounted in pairs to prevent bridging and ensure even feeding down on to the belt. These can be removed depending on the type of material used.

CHAIN DRIVE AGITATOR



The Shelbourne Cubicle Bedder can be used on a wide range of materials including sawdust, wood shavings, processed paper, chopped straw and sand.

◀ OPTIONAL 3 POINT LINKAGE BRACKETS

FLOW CONTROL VALVE



BELT DRIVE



“ THE SAME MACHINE CAN SPREAD SAND, SAWDUST, ENVIROBED, STRAW, GREEN BEDDING, LIME AND STRAW, GYPSUM AND EVERYTHING ELSE WE HAVE COME ACROSS TO DATE! ”

# Shelbourne

## CUBICLE BEDDER TECHNICAL DATA

FIND US:



	100	150	300
Capacity (cubic metres)	0.6m	1.2m	1.45m
Overall Height (A)	1170mm (3'10")	1390mm (4'7")	1390mm (4'7")
Overall Depth (F)	1235mm (4'1")	1420mm (4'8")	1420mm (4'8")
Overall Width (C)	1600mm (5'3")	1900mm (6'3")	2200mm (7'3")
Tub Width (D)	1370mm (4'6")	1670mm (5'6")	1970mm (6'6")
Tub Depth (B)	1150mm (3'10")	1390mm (4'7")	1390mm (4'7")
Width of Discharge Belt (E)	300mm (1')	300mm (1')	300mm (1')
Standard Hydraulic Motors	30-35 l/min	30-35 l/min	30-35 l/min
Medium Flow Hydraulic Motors	24-28 l/min	24-28 l/min	24-28 l/min
Low Flow Hydraulic Motors	15-22 l/min	15-22 l/min	15-22 l/min
Min Hydraulic Pressure	125 bar	125 bar	125 bar
Weight	420kg	530kg	585kg
Min Tractor Size	30hp	40hp	50hp

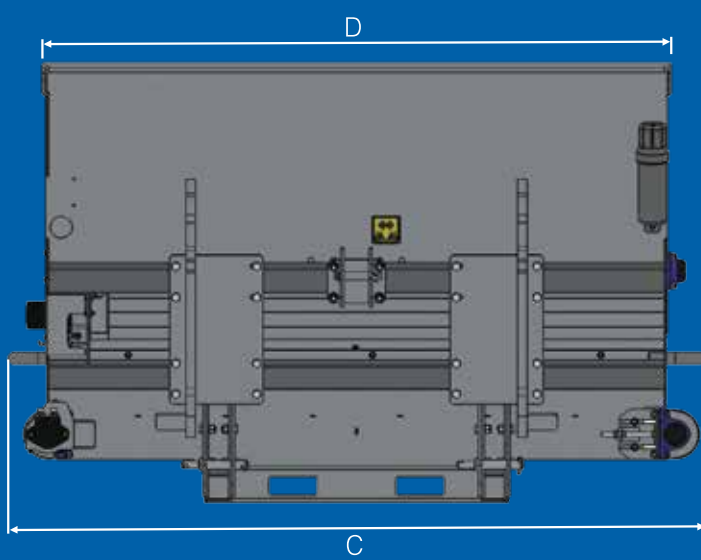
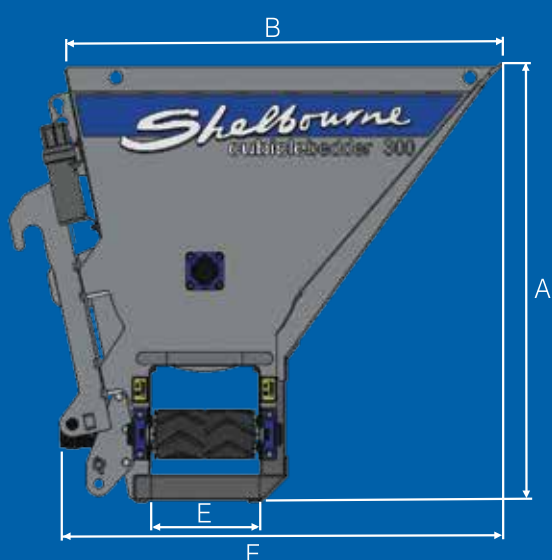

**SHELBOURNE REYNOLDS  
ENGINEERING LTD.**

SHEPHERDS GROVE, STANTON, BURY ST EDMUNDS,  
SUFFOLK, IP31 2AR T: 01359 250415 F: 01359 250464  
SHELBOURNE.COM